

51

Valvola a flusso avviato a vite interna
con soffietto in ghisa grigia, esente manutenzione

Cast iron streamlined flow valve **inside screw** with bellows, maintenance free

Caratteristiche principali di serie Main standard features

- **Volantino saliente**
Rising handwheel
- **Stelo rotante**
Rotating stem
- **Otturatore non rotante**
Not rotating disc
- **Sede mandrinata**
Pressed-in seat

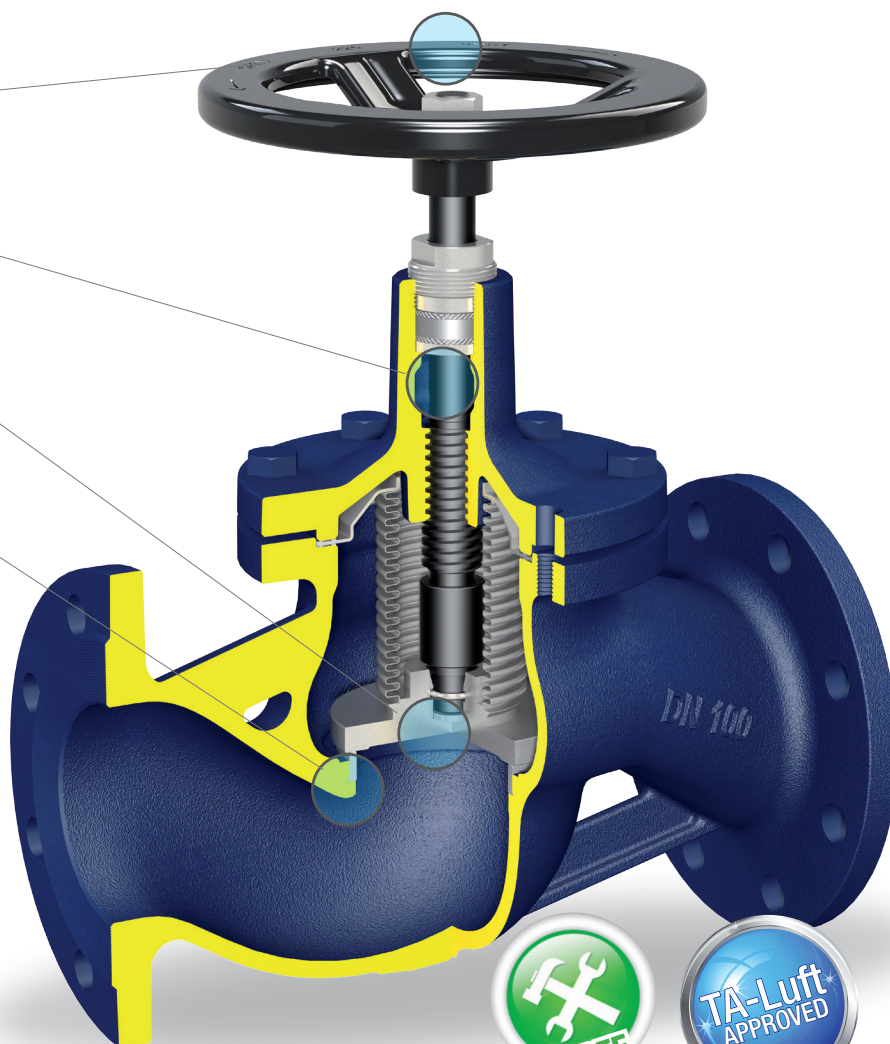

Possibili campi di impiego Application

Impianti di trasmissione calore, centrali termiche, caldaie e serbatoi, ecc.

Heat transfer systems, thermal power stations, industrial boilers and tanks, etc.

Adatte per Suitable for

Acqua calda e/o surriscaldata, vapore, aria, ecc.

Hot water and/or overheated water, steam, air, etc.

Materiali Materials

POS.	Componente	Components	Material
1	Corpo	Body	EN-GJL-250
2	Cappello	Bonnet	EN-GJL-250
3	Sede	Seat	St. Steel 1.4021
4	Otturatore	Disc	St. Steel 1.4021
5	Stelo	Stem	St. Steel 1.4021
6	Soffietto	Bellows	St. Steel 1.4541
7	Disco antifrizione	Antifriction disk	St. Steel 1.4021
8	Guarnizioni	Gaskets	Graphite + St. Steel
9	Baderna	Packing	Graphite
10	Volantino	Handwheel	Pressed steel
11	Viti	Screws	Carbon steel

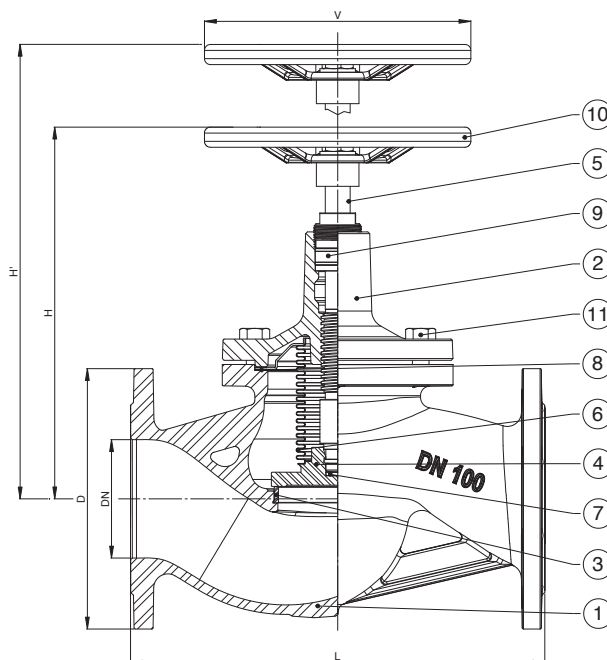

Dimensioni Sizes

DN	D	L	H	H'	V	Kg	Kv
	mm	mm	mm	mm	mm		m ³ /h
15	95	130	165	175	100	3	4,6
20	105	150	165	175	100	3,7	7,3
25	115	160	185	195	100	4,4	11,7
32	140	180	185	195	125	6,1	16,8
40	150	200	215	230	150	9,3	26,7
50	165	230	215	230	150	11,2	42,6
65	185	290	295	315	200	19	77,9
80	200	310	295	315	200	21,5	111
100	220	350	320	355	225	31,5	177
125	250	400	345	385	250	42,5	262
150	285	480	400	445	350	64,5	368
200	340	600	455	520	400	111	664

KV alla percentuale di alzata figura 51/R

Kv at stroke rate item 51/R

DN	15	20	25	32	40	50	65	80	100	125	150	200
20%	0.33	0.84	1.3	2.2	3.72	8.26	8.91	16.1	21.1	35.9	51.1	72
40%	0.99	1.77	2.81	4.53	7.24	14.2	18	30.9	40.4	60.9	109	143
60%	2.17	3.52	4.91	8.3	13.5	22.2	34.2	55.2	74.6	103	190	258
80%	3.27	5.47	7.64	12.5	19.8	30.8	53.8	80.4	117	154	252	377
100%	4.19	6.77	9.22	15.4	24.5	36.5	64.1	91.7	138	182	286	446

Condizioni di esercizio/ Working conditions

Temperatura - Temperature [°C]	-10/120	150	200	250	300
Pressione - Pressure [bar]	16	14,4	12,8	11,2	9,6

Varianti costruttive Manufacturing variations

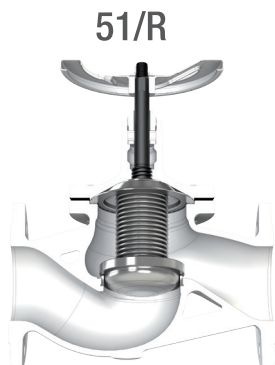

Otturatore a profilo parabolico di regolazione
Regulating disc

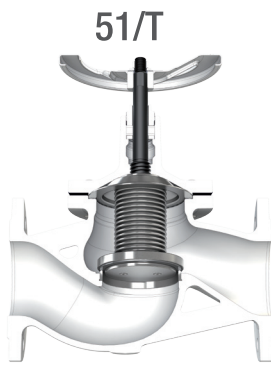

Otturatore a tenuta morbida di PTFE intercambiabile
Soft sealing interchangeable PTFE disc

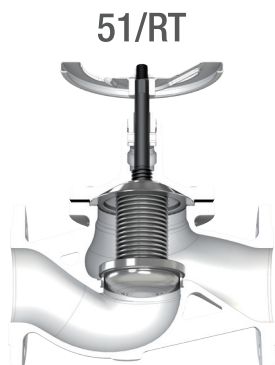
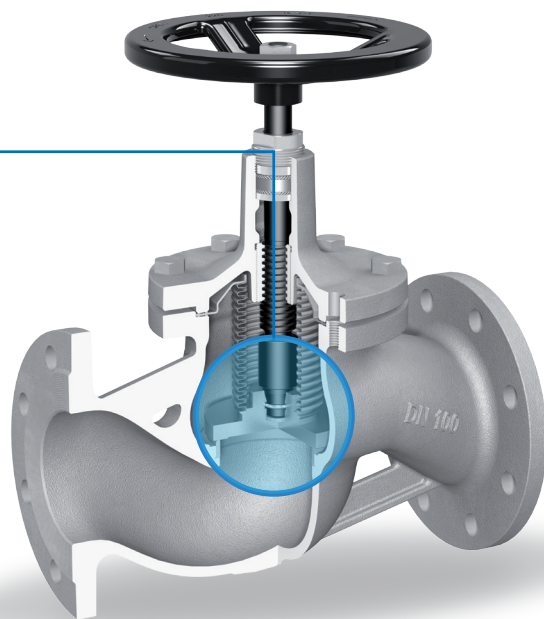

Otturatore a profilo parabolico di regolazione a tenuta morbida di PTFE intercambiabile
Regulating disc with soft sealing interchangeable PTFE disc

Articolo distribuito da:

TECNODISTRIBUZIONE S.r.l.

Via Nataloni, 27 - 47922 Rimini (RN) - Italy
Tel.: +39 0541 790808 Fax: +39 0541 790144
E-mail: td@tecnodistribuzione.it
www.tecnodistribuzione.it