



3A.112-E
Issue 6.1 - 2016

GKE Ball Float Steam Trap

Description

The GKE series float steam traps are manufactured with nodular iron body; internal components are made from stainless steel. They are suitable for use with saturated and superheated steam on process equipments and on medium / high consumption applications.

Working is fully automatic also regarding air venting (bimetallic thermo element) while the condensate discharge has modulating characteristics. These traps are ideal for all process drainage applications as condensate is always removed efficiently and quickly over a wide range of fluctuating pressures and load conditions; they meet all the needs and demands of process automatic control systems.

To facilitate the installation on the plant, the mounting connections can be easily positioned in four different way.

For more demanding applications, higher pressure and temperature, see the similar GHE series manufactured with carbon or stainless steel body.

Standards

This product fully complies with the requirements of the European Pressure Equipment Directive 2014/68/EU and carries the CE mark when so required.

Certification

The product is available with material certification to EN 10204 2.2 or EN 10204 3.1.

Note: all certification/inspection requirements must be stated at the time of order placement.



Sizes and pipe connections

DN 40 and DN 50 flanged EN 1092 PN 25/40, standard
DN 40 and DN 50 flanged ANSI B 16.5 Class 150 and 300, on request
1½" and 2" screwed UNI-ISO 7/1 Rp (gas), on request

Pressure/temperature limits

PMA - Maximum allowable pressure 25 bar g @ 300°C

TMA - Maximum allowable temperature 300°C

Minimum allowable temperature -10°C

PMO - Maximum operating pressure 21 bar g @ 300°C

TMO - Maximum operating temperature 300°C

Minimum operating temperature, danger of freezing considered 0°C

ΔPMX - Maximum differential pressure GKE 10 10 bar g

GKE 21 21 bar g

Designed for a maximum cold hydraulic test pressure of 37.5 bar g

Note: maximum operating pressure can be limited by the rating chosen for the flanges.

Materials

N° Part	Material
1 Body	SG iron GJS400 18 LT UNI 1563
2 Cover	SG iron GJS400 18 LT UNI 1563
3 Cover gasket	Asbestos-free synthetic fibre
4 Air vent assembly	Stainless steel
5 Bracket gasket	Asbestos-free synthetic fibre
6 Bracket assembly	Stainless steel AISI 304
7 Bracket screws	Stainless steel AISI 304
8 Lower valve seat	Stainless steel Series 400C
9 Valve plug	Stainless steel Series 400C
10 Float arm	Stainless steel AISI 304
11 Ball float	Stainless steel AISI 304
12 Drain plug	Carbon steel ASTM A105
13 Cover studs	Carbon steel ASTM A193 B7
13 Cover nuts	Carbon steel ASTM A194 8M

Capacities (kg/h)

The condensate discharge capacities shown below are based on condensate at saturation temperature.

Differential pressure (bar g)	Trap type			
	GKE 10 DN 40 - 1½"	GKE 10 DN 50 - 2"	GKE 21 DN 40 - 1½"	GKE 21 DN 50 - 2"
0.1	1500	3600	1000	1900
0.3	2500	6000	1700	3300
0.5	3200	7700	2150	4100
0.7	3700	8900	2450	4800
1	4300	10600	2900	5700
1.5	5200	12500	3500	6800
2	6000	14100	4000	7800
4	8400	20000	5500	10500
7	11000	26000	7300	13500
10	13000	30500	8500	16300
12	--	--	9400	18000
14	--	--	10000	19000
18	--	--	12000	21500
21	--	--	12300	22500

The choice of trap should be based on the following data:

- Hourly amount of condensate to be discharged,
- Effective differential pressure,
- Safety factor: 1.25 to 1.5 for continuous use; 2 to 3 for intermittent use.

Dimensions/weights (approximate) in mm and kg

DN	A	A1	B	C	D	E*	Weight Scrd.	Weight Fldg.
1½" - 40	320	324	280	120	300	480	25.0	30.0
2" - 50	320	324	280	120	300	480	25.0	32.0

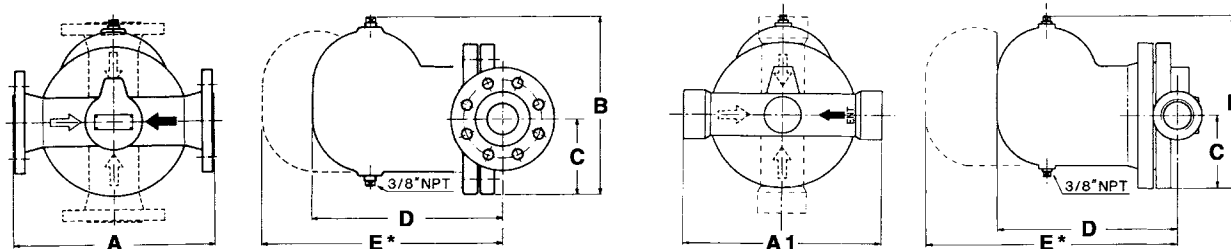

Connections:

- Black arrow: standard supply configuration (right to left)
- White arrows: optional installation configurations, on request

* Withdrawal distance

How to order

Example: N° 1 off ball float steam trap Spirax Sarco GKE 21, with SG iron body and stainless steel internal components. Maximum operating and differential pressure 21 bar. Flanged connections according to EN 1092 PN 40 DN 50.

How to order spares

Always order spare parts by using the description given in the table and state the size and type of trap, including pressure range and type of the connections.

Example: N° 1 main valve assembly for a ball float steam trap Spirax Sarco GKE 10, DN 1½".

Safety information, installation and maintenance

For full details see the Installation and Maintenance Instructions 3.341.5275.245 supplied with the product.

Installation note

The traps must be installed below the draining point and, with low operating pressures or when in presence of automatic temperature control, assure a hydrostatic head of about 1 metre between the drainage outlet and the trap.

Make the connections so that the trap is positioned with the arrow on the body pointed vertically downwards.

The use of an upstream protection strainers is always recommended to prevent possible damage to the internal components and to assure regular working operation.

To permit a safe inspection for cleaning or maintenance purpose install suitable shut-off valves. If the trap is to discharge to atmosphere ensure it is to a safe place, the discharging fluid may be at a temperature of 100°C.

Disposal

The product is recyclable. No ecological hazard is anticipated with the disposal of this product providing due care is taken.

Spare parts

The spare parts are shown in the drawing by the side and are available in groupings as indicated in the table. Other parts are not available as spare.

Available spares

Main valve assembly	3, 5, 6, 7, 8, 9, 10
Ball float and cover gasket assembly	3, 11
Air vent assembly (2 off)	4
Gasket set (3+3 off)	3, 5

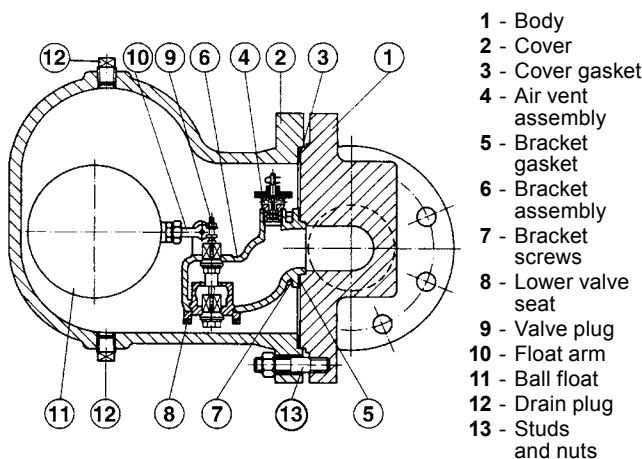

Recommended tightening torques

Item	Size	or mm	N m	
Cover nuts	1½" - 40	24 A/F	M 16 x 70	90
	2" - 50	24 A/F	M 16 x 70	90
Bracket screws	1½" - 40		M 8 x 15	18.2
	2" - 50		M 8 x 15	18.2